

STANDARD FEATURES

- Size: 175*70mm
- Operating Temperature: -10°C to +70°C
- Storage Temperature: -40°C to +85°C
- Weight: 800g
- Bearing System: Dual Sealed Ball Bearings
- Impeller: Mg. Alloy integrated die-casing, surface treatment(ED coating+powder coating)
- Motor Base: Die Cast Aluminum
- Lead Wires: 450MM



BENEFITS

- Outstanding CFM performance in high pressure systems
- 18 months warranty
- Extended bearing life
- Soft start capability
- Designed with optional features RD, Tach/FG, PWM,0-10V
- This fan is designed for continuous duty life of 55000 hours at 40°C (L10)

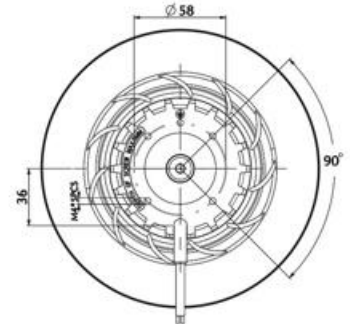
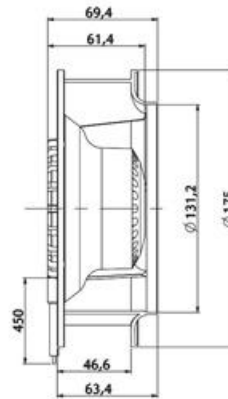
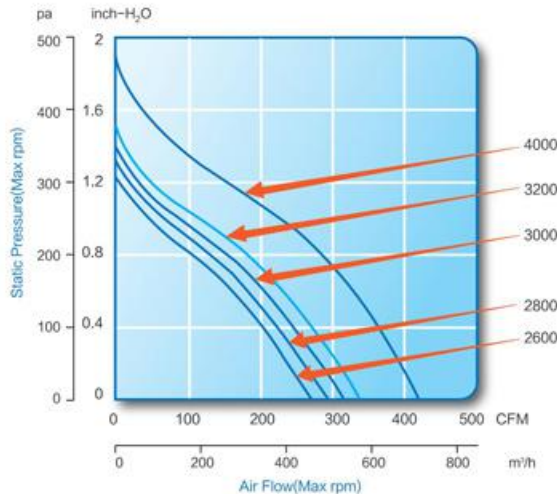

參數表 Specification

Model	Rated Voltage (V)	Freq (HZ)	Current (mA)	Power (W)	Speed (rpm)	Air Flow		Max.Static Pressure(H ₂ O)		Noise Leve (dB-A)	Weight (g)
						M ³ /Min.	CFM	MM	INCH		
KU175A2800D12B	12VDC	-	2167	26	2800	8.24	294	34.04	1.34	69	800
KU175A3200D12B	12VDC	-	3083	37	3200	9.41	336	38.86	1.53	73	800
KU175A2800D24B	24VDC	-	1083	26	2800	8.24	294	34.04	1.34	69	800
KU175A3200D24B	24VDC	-	1542	37	3200	9.41	336	38.86	1.53	73	800
KU175A2800D48B	48VDC	-	542	26	2800	8.24	294	34.04	1.34	69	800
KU175A3200D48B	48VDC	-	771	37	3200	9.41	336	38.86	1.53	73	800
KU175A4000D48B	48VDC	-	1563	75	4000	11.76	420	48.58	1.91	79	800
KU175A2800D110B	110VDC	-	236	26	2800	8.24	294	34.04	1.34	69	890
KU175A3200D110B	110VDC	-	336	37	3200	9.41	336	38.86	1.53	73	890
KU175A2600E0B	100-240VAC	50-60	420-260	23-25	2600	7.65	273	31.5	1.24	67	890
KU175A3000E0B	100-240VAC	50-60	500-280	32-36	3000	8.82	315	36.32	1.43	69	890